



carmanah®
we put solar to work

MODEL

R247

24-HOUR SOLAR LED FLASHING BEACON

Typical Applications:

- Warning signs
- Stop signs

Improves Safety

- Flashes 24 hours per day, 365 days per year
- Improves driver awareness by increasing sign visibility
- Enhances safety for a broad range of roadway treatments

Reliability Assured

- Core energy management system ensures operation; even during periods of cloud cover
- Turn-key system custom configured for optimum performance based on location, solar insolation and desired operation

Cost-Effective Solution

- No trenching, wiring or digging required
- "Plug-and-play" installation for reduced disruption to traffic
- Cabinet-free, sturdy design inhibits vandalism

Easy Installation and Operation

- Installs to existing sign posts within thirty minutes
- Easy to relocate and repurpose to other locations

Quality Ensured

- Manufactured in facilities certified to ISO quality standards
- Designed and assembled in North America
- Backed by a 3-year limited warranty



INSTALLATIONS AND APPLICATIONS



REDUCE SPEED MARKER -
FREMONT, CA



INTERSECTION AHEAD -
MORINVILLE, AB

REPRESENTED IN YOUR REGION BY:

MOUNTING EXAMPLES

DUAL BEACON

Dual - Horizontal Top Pole Mount

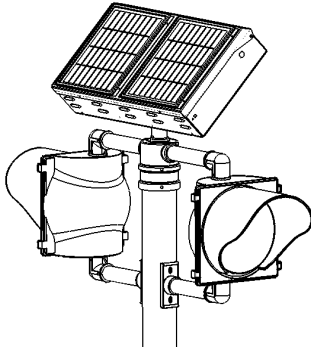

Dual - Vertical Top Pole Mount

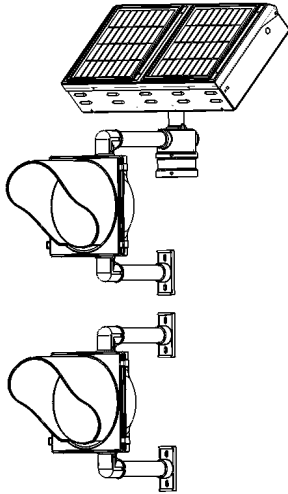

OTHER MOUNTING OPTIONS AVAILABLE
PRODUCT MAY NOT BE EXACTLY AS SHOWN

COMPONENT	DIMENSION		
	Length	Width	Height
Single Beacon	25.0" (635 mm)	15.0" (381 mm)	33.5" (851 mm)
20 W Engine	15.75" (401 mm)	29.3" (743 mm)	6.0" (151 mm)

* Dimensions may vary based on pole selection, 45° tilt and beacon configuration.

Performance is tied to solar availability and geographic location.



SPECIFICATIONS SUBJECT TO CHANGE WITHOUT NOTICE.

US Patent No 6,573,659, Other patents pending. "Carmanah" and Carmanah logo are trademarks of Carmanah Technologies Corp.

© 2016, Carmanah Technologies Corp.
Document: SPC_TRAF_R247_RevR

MODEL

R247 SERIES

24-HOUR SOLAR LED FLASHING BEACON

OPERATION

Flash pattern	MUTCD* compliant Alternate, unison, and quick-flash
---------------	--

LED SIGNAL MODULE

Standard	ITE VTCSH LED circular signal supplement
Size and LED colour	12" (305 mm) diameter amber or red 8" (203 mm) diameter amber or red

ENVIRONMENTAL

Operating temperature range	5 to 122° F (-15 to 50° C)
Extended temperature range (optional)	-40 to 122° F (-40 to 50° C)

ENERGY MANAGEMENT SYSTEM

Autonomous profile	24/7
Battery lifespan	3 – 5 years (field replaceable)
Automatic light control (ALC)	Systems continue to provide useful light during extreme conditions that prevent charging over an extended period of time

MOUNTING HARDWARE

Bracket options for standard sign posts	4 ½" (114 mm) round Pelco traffic signal mounting hardware
Colour	Black, yellow or green
Wind load rating	178 km/h (110 mph) **

COMPONENTS

Solar panel	High-efficiency 20 W panel
Battery	Replaceable, recyclable best-in-class battery pack. Sealed, maintenance-free.
Light source	Ultra-bright LEDs featuring innovative optic and lens design for optimum light divergence
Construction	Fully self-contained weather, corrosion and vandal-resistant unit with premium-grade UV-resistant head.

QUALITY STANDARDS

Quality certification	ISO Certified Manufacturer
Certification	System compliant with Buy American Act

WARRANTY

Term	3-year limited warranty
------	-------------------------

* Meets all requirements for design, illumination, and colour of signal sections required by MUTCD 2009, Chapter 4L, Flashing Beacons. MUTCD: Manual on Uniform Traffic Control Devices.

** 3 second gust as per AASHTO 2001.



Pb

